

PARTIAL SIDE VIEW

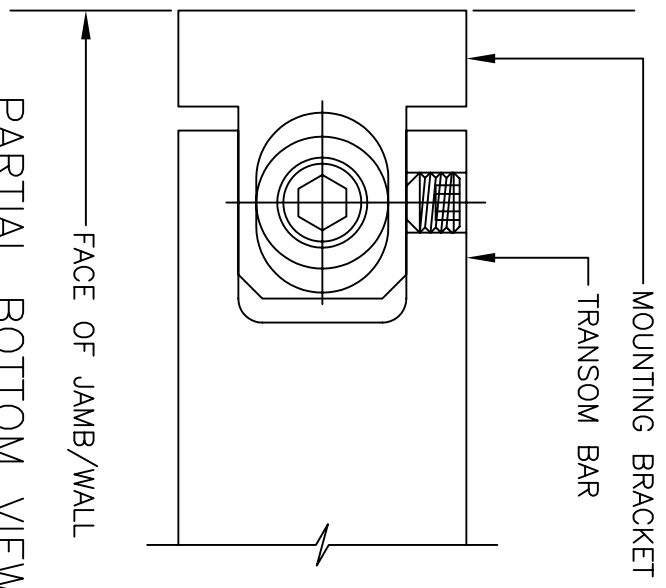
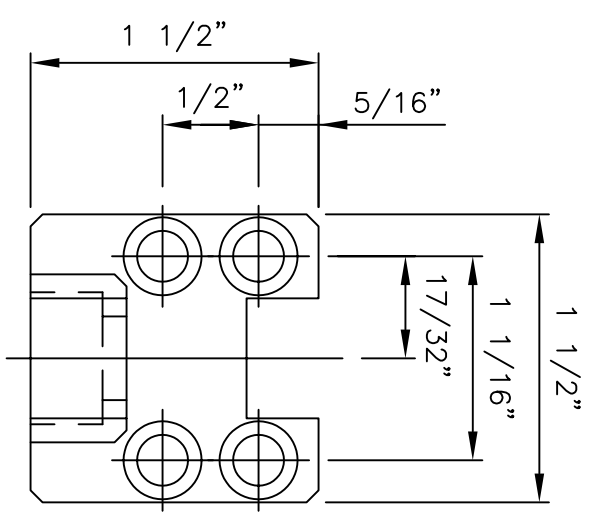

PARTIAL BOTTOM VIEW

TOLERANCES: $\pm .005$ DECIMALS $\pm \frac{1}{64}$ FRACTIONS

REVISIONS	DATE	DN	CH

UNLESS OTHERWISE SPECIFIED

Blumcraft OF PITTSBURGH

DRAWN BY KC 7/13/05

CHECKED BY -

SCALE FULL

B-1250 FLUSH WALL MOUNT

DWG. NO. CAD-1301TB-4

SHEET 1 OF 1